

Stock No.	9001	Reg.Year	2003	Seatbelt.Year	2003	Transmission	(AT) / MT
Model	Noah	Mileage (KM)	96202	Doors / Seats	5 / 1	Fuel	(Petrol) / Diesel / Hybrid
Grade	5D	Engine (CC)	1990	Engine Type	1A2	Steering	(Right) / Left
Chassis No.	AZR 60-0207127			Timing Belt	(Chain) / Rubber	Drive Type	(2WD) / 4WD

Record (J)	<input checked="" type="checkbox"/> CD	<input type="checkbox"/> AC	<input checked="" type="checkbox"/> P.Mirror	<input checked="" type="checkbox"/> Highroof	<input type="checkbox"/> Wood Panel	<input type="checkbox"/> Alloy Wheel	<input type="checkbox"/> Spare Key	<input checked="" type="checkbox"/>
Manual (J)	<input checked="" type="checkbox"/> CD Changer	<input type="checkbox"/> AC (Rear)	<input checked="" type="checkbox"/> P.Seat	<input type="checkbox"/> Sunroof	<input type="checkbox"/> Digital Meter	<input type="checkbox"/> Spoiler	<input type="checkbox"/> Remote Key	<input checked="" type="checkbox"/>
TV	<input type="checkbox"/> USB	<input type="checkbox"/> Air Bag	<input checked="" type="checkbox"/> P.Locking	<input checked="" type="checkbox"/> Sliding Door	<input checked="" type="checkbox"/> Leather Seat	<input type="checkbox"/> Grill Guard	<input type="checkbox"/> Smart Key	<input type="checkbox"/>
Navi (J)	<input type="checkbox"/> MD	<input type="checkbox"/> Air Bag (P)	<input checked="" type="checkbox"/> ABS	<input checked="" type="checkbox"/> Sliding Electric	<input type="checkbox"/> Sport AT	<input type="checkbox"/> Back Tire	<input type="checkbox"/> Immobilizer	<input type="checkbox"/>
Back Monitor	<input type="checkbox"/> Cassette	<input type="checkbox"/> P.Steering	<input checked="" type="checkbox"/> ESC	<input type="checkbox"/> Full Flat	<input checked="" type="checkbox"/> Turbo	<input type="checkbox"/> Rear Wiper	<input checked="" type="checkbox"/>	<input type="checkbox"/>
AM/FM (J)	<input type="checkbox"/>	<input type="checkbox"/> P.Window	<input checked="" type="checkbox"/> HID	<input checked="" type="checkbox"/>	<input type="checkbox"/>	<input type="checkbox"/> Fog Light	<input type="checkbox"/>	<input type="checkbox"/>

Exterior (Body)

Interior (Inside)

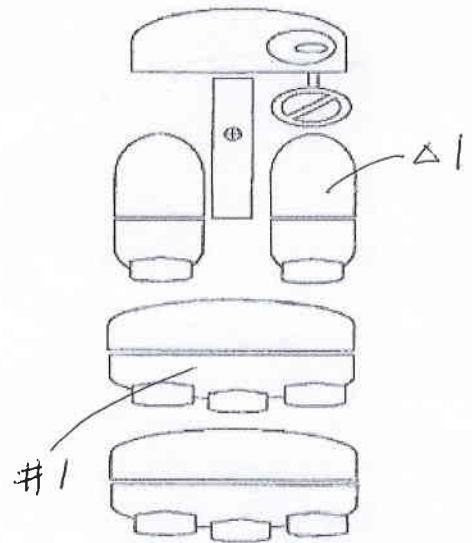
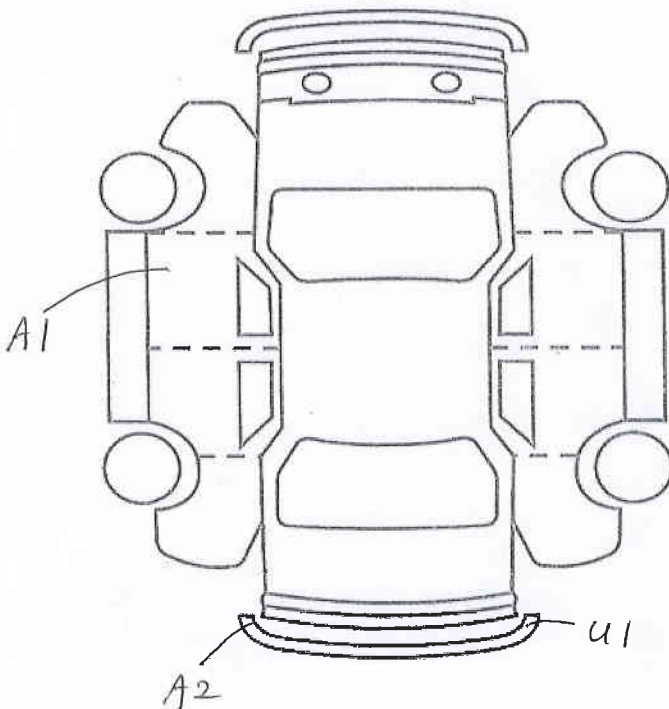

NOTE !

No report that is judged as minor and non-need of mention or invisible including slight, tiny, and hair-line scratches and stains.

Marking	A	Scratch	U	Dent	B	Dent & Scratch	Y	Crack
	S	Rust	C	Corrosion	P	Peeling	G	Stone Chip
	W	Repaired or Painted		xx	Replaced	X	Need Replaced	

Marking	#	Stain	~	Tear
	Δ	Cigar Burn	○	Hole
	//	Dirt		

Size	1	Slight	2	Small	3	Medium
	4	Large	5	Heavy		

Size	1	Small	2	Medium
	3	Large		

Our Inspection Points (alignment, rickteness, leak, damage, etc)				General & New Parts Replacement	
Steering Gear Box	OK / FAULT	Handling	OK / FAULT	Engine Oil / Filter	NEW / OK / BAD
Steering Rod / Arm	OK / FAULT	Suspension System	OK / FAULT	Battery	NEW / OK / BAD
Transmission	OK / FAULT	Shock Absorber	OK / FAULT	Brake Oil	NEW / OK / BAD
Propeller Shaft	OK / FAULT	Wheel / Tires	OK / FAULT	Coolant Fluid	NEW / OK / BAD
Differential Gear	OK / FAULT	Brake Disk / Drum	OK / FAULT	Window Liquid	NEW / OK / BAD
Brake Hose / Pipe	OK / FAULT	Master Cylinder	OK / FAULT	Wiper Rubber	NEW / OK / BAD
Exhaust Muffler	OK / FAULT	Disk Caliber	OK / FAULT	Fan Belt	NEW / OK / BAD
Power Steering	OK / FAULT	Body Frame	OK / FAULT	Brake Pad	NEW / OK / BAD
Ignition System	OK / FAULT	Seat Belt	OK / FAULT	Air Cleaner	NEW / OK / BAD
Cooling System	OK / FAULT	Lights & Lamps	OK / FAULT	AC Gas	NEW / OK / BAD
Fuel System	OK / FAULT			Spark Plug	NEW / OK / BAD
Electric Wiring	OK / FAULT			Engine	OK / FAULT Noise / Slag / Oil Leak / Water
Engine Motor	OK / FAULT			Exhaust Gas	OK / FAULT Abnormal Color / Amount
Clutch Pedal	OK / FAULT			Warning Lamps	OK / FAULT SRS / ABS / Engine / Oil
Brake Pedal	OK / FAULT	Parts Missing	NO / YES	Electrics	OK / FAULT AC / PS / PW / PM
Parking Brake	OK / FAULT	Parts In Car	NO / YES	Rust	OK / (MINOR) / BAD Under Body / Engine Room / Boots

Inspector : 長島

Date : 10 / 8 / 2014